

6" Dome Housing

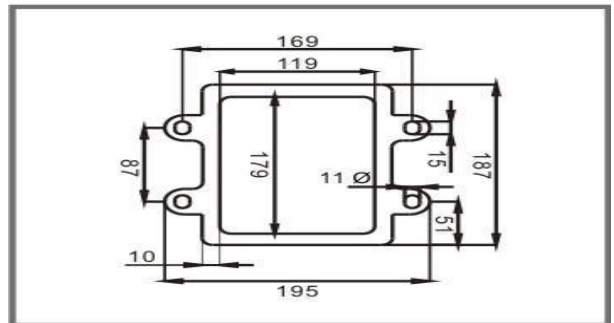
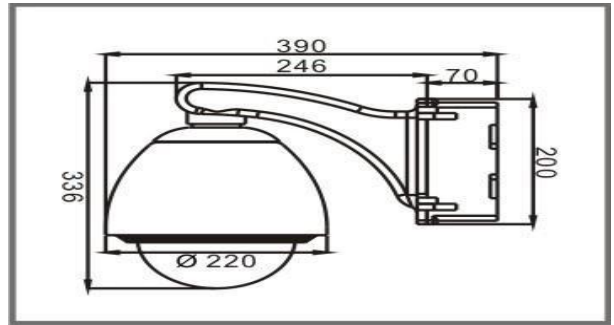

MODEL	AV-H001/H001P/H003P
Aluminum Alloy Enclosure	
6" Aluminum Dome Enclosure, suitable for outdoor and indoor installation.	
Double-decked design strengthens the heat insulation.	
Meet IP66 protection level.	
Build-in Fan & Heat make sure the mechanism works in a certain temperature. (Option)	
Wall mounts bracket or pendant mount bracket selectable.	
A stainless steel retaining cable.	
Power Box. (Option)	
PPG Lumiflon : enduring environment, resistible acid & base, five years warrant.	