



Product Specification

P270HVN01.0

AU OPTRONICS CORPORATION

() Preliminary Specification

(V) Final Specification

Module	27.0" Color TFT-LCD
Model Name	P270HVN01.0

Customer	Date
_____	_____
Approved by	
_____	_____

Approved by	Date
<u>Howard Lee</u>	<u>2013/5/20</u>
Prepared by	Date
<u>Rafael</u>	<u>2013/5/24</u>

Note: This Specification is subject to change without notice.

Desktop Display Business Group /
AU Optronics Corporation

Contents

1 Handling Precautions	5
2 General Description	6
2.1 Display Characteristics.....	6
2.2 Absolute Maximum Rating of Environment	7
2.3 Optical Characteristics	8
2.4 Mechanical Characteristics	錯誤! 尚未定義書籤。
3 TFT-LCD Module	13
3.1 Block Diagram.....	13
3.2 Interface Connection.....	14
3.2.1 Connector Type.....	14
3.2.2 Connector Pin Assignment.....	14
3.3 Electrical Characteristics.....	16
3.3.1 Absolute Maximum Rating	16
3.3.2 Recommended Operating Condition.....	16
3.4 Signal Characteristics	17
3.4.1 LCD Pixel Format.....	17
3.4.2 LVDS Data Format.....	17
3.4.3 Color versus Input Data	18
3.4.4 LVDS Specification.....	19
3.4.5 Input Timing Specification	21
3.4.6 Input Timing Diagram	22
3.5 Power ON/OFF Sequence	23
4 Backlight Unit	24
4.1 Block Diagram.....	24
4.2 Interface Connection.....	25
4.2.1 Connector Type.....	25
4.2.2 Connector Pin Assignment.....	27
4.3 Electrical Characteristics.....	28
4.3.1 Absolute Maximum Rating	28
4.3.2 Recommended Operating Condition.....	28
5 Reliability Test.....	30
6 Shipping Label	31
7 Mechanical Characteristics	32
8 Packing Specification	35
8.1 Packing Flow.....	35
8.2 Pallet and shipment information.....	36

Record of Revision

Version	Date	Page	Description																												
0.0	2012/11/30		First release																												
0.1	2012/12/20	34	To Modify the Ch 11-2 Panel dimension with 613.6(H)mm x 356.85(V)mm x 10(D)mm																												
		18	To Correct the Note3 , VLED changed VLB																												
			Re-named the LVDS Signal <table border="1"> <thead> <tr> <th>Pin#</th> <th>Signal Name</th> <th>Pin#</th> <th>Signal Name</th> </tr> </thead> <tbody> <tr> <td>1</td> <td>RX00-</td> <td>2</td> <td>RX00+</td> </tr> <tr> <td>3</td> <td>RX01-</td> <td>4</td> <td>RX01+</td> </tr> <tr> <td>5</td> <td>RX02-</td> <td>6</td> <td>RX02+</td> </tr> <tr> <td>7</td> <td>GND</td> <td>8</td> <td>RXOCLK-</td> </tr> <tr> <td>9</td> <td>RXOCLK+</td> <td>10</td> <td>RX03-</td> </tr> <tr> <td>11</td> <td>RX03+</td> <td>12</td> <td>RX03-</td> </tr> </tbody> </table>	Pin#	Signal Name	Pin#	Signal Name	1	RX00-	2	RX00+	3	RX01-	4	RX01+	5	RX02-	6	RX02+	7	GND	8	RXOCLK-	9	RXOCLK+	10	RX03-	11	RX03+	12	RX03-
Pin#	Signal Name	Pin#	Signal Name																												
1	RX00-	2	RX00+																												
3	RX01-	4	RX01+																												
5	RX02-	6	RX02+																												
7	GND	8	RXOCLK-																												
9	RXOCLK+	10	RX03-																												
11	RX03+	12	RX03-																												
		29	Update shipping label																												
0.2	2012/01/29	10	Remove page 10																												
		12 18 26	old naming <table border="1"> <thead> <tr> <th>Symbol</th> <th>Description</th> </tr> </thead> <tbody> <tr> <td>IRLED1</td> <td rowspan="4">LED Forward Current</td> </tr> <tr> <td>IRLED2</td> </tr> <tr> <td>IRLED3</td> </tr> <tr> <td>IRLED4</td> </tr> <tr> <td>VLB</td> <td>Light Bar Operation Voltage (for reference)</td> </tr> </tbody> </table> New <table border="1"> <thead> <tr> <th>Symbol</th> <th>Description</th> </tr> </thead> <tbody> <tr> <td>IFLED1</td> <td rowspan="4">LED Forward Current</td> </tr> <tr> <td>IFLED2</td> </tr> <tr> <td>IFLED3</td> </tr> <tr> <td>IFLED4</td> </tr> <tr> <td>VSLED</td> <td>Light Bar Operation Voltage (for reference)</td> </tr> </tbody> </table>	Symbol	Description	IRLED1	LED Forward Current	IRLED2	IRLED3	IRLED4	VLB	Light Bar Operation Voltage (for reference)	Symbol	Description	IFLED1	LED Forward Current	IFLED2	IFLED3	IFLED4	VSLED	Light Bar Operation Voltage (for reference)										
Symbol	Description																														
IRLED1	LED Forward Current																														
IRLED2																															
IRLED3																															
IRLED4																															
VLB	Light Bar Operation Voltage (for reference)																														
Symbol	Description																														
IFLED1	LED Forward Current																														
IFLED2																															
IFLED3																															
IFLED4																															
VSLED	Light Bar Operation Voltage (for reference)																														
1.0	2013/05/24	all	New format update																												
		7	To define the maximum value of response time																												
		7	Color Coordinates By update(0.064→0.055)																												
		32-34	Adding mylar on front bezel surface, drawing updated																												
		28	Recommendation for LED driver power design: To Modify the Maxmium of Power is 23.76(24.95→23.76)																												
		35-36	After modifying , the packing box is 10pcs/Box and the weight of pallet of packing is 229.94kg.(9pcs/box→10pcs/box; 216kg→229.94kg)																												



Product Specification

P270HVN01.0

AU OPTRONICS CORPORATION

1 Handling Precautions

- 1) Since front polarizer is easily damaged, pay attention not to scratch it.
- 2) Be sure to turn off power supply when inserting or disconnecting from input connector.
- 3) Wipe off water drop immediately. Long contact with water may cause discoloration or spots.
- 4) When the panel surface is soiled, wipe it with absorbent cotton or other soft cloth.
- 5) Since the panel is made of glass, it may break or crack if dropped or bumped on hard surface.
- 6) Since CMOS LSI is used in this module, take care of static electricity and insure human earth when handling.
- 7) Do not open or modify the Module Assembly.
- 8) Do not press the reflector sheet at the back of the module to any directions.
- 9) In case a TFT-LCD Module has to be put back into the packing container slot after once it was taken out from the container, do not press the center of the LED lightbar edge. Otherwise the TFT-LCD Module may be damaged.
- 10) Insert or pull out the interface connector, be sure not to rotate nor tilt it of the TFT-LCD Module.
- 11) Do not twist nor bend the TFT -LCD Module even momentary. It should be taken into consideration that no bending/twisting forces are applied to the TFT-LCD Module from outside. Otherwise the TFT-LCD Module may be damaged.
- 12) Please avoid touching COF position while you are doing mechanical design.
- 13) When storing modules as spares for a long time, the following precaution is necessary:
Store them in a dark place. Do not expose the module to sunlight or fluorescent light. Keep the temperature between 5°C and 35°C at normal humidity.



2 General Description

This specification applies to the 27 inch-FHD Color a-Si TFT-LCD Module P270HVN01.0. The display supports the FHD - 1920(H) x 1080(V) screen format and 16.7M colors (RGB 8-bit data). The light source of this TFT-LCD module is W-LED. The input interface is Dual channel LVDS and this module doesn't contain an driver board for backlight.

2.1 Display Characteristics

The following items are characteristics summary on the table under 25°C condition:

ITEMS	Unit	SPECIFICATIONS
Screen Diagonal	[mm]	685.65(27.0")
Active Area	[mm]	597.6 (H) x 336.15 (V)
Pixels H x V	-	1920(x3) x 1080
Pixel Pitch	[um]	311.25 (per one triad) x311.25
Pixel Arrangement	-	R.G.B. Vertical island
Display Mode	-	VA Mode, Normally Black
White Luminance (Center)	[cd/m ²]	350 cd/m ² (Typ.) @ 110mA 300 cd/m ² (Typ.) @ 100mA
Contrast Ratio	-	3000 (Typ.)
Response Time	[msec]	12ms (Typ., on/off)
Power Consumption (LCD Module + Backligh unit)	[Watt]	26.88 watt VDD line : PDD (typ), All white pattern at 60Hz = 5.1 W LED line : PBLU (typ) = 21.78 W(@110mA)
Weight	[Grams]	2180 gram (Typ.)
Outline Dimension	[mm]	613.6(H)x356.85(V)x10.0(D) (Typ.)
Electrical Interface	-	Dual channel LVDS
Support Color	-	16.7M colors (RGB 8-bit)
Surface Treatment	-	Anti-Glare 3H
Temperature Range Operating	[°C]	0 to +50
Storage (Shipping)	[°C]	-20 to +60
RoHS Compliance	-	RoHS Compliance
TCO Compliance	-	TCO 6.0 Compliance

2.2 Absolute Maximum Rating of Environment

Permanent damage may occur if exceeding the following maximum rating.

Symbol	Description	Min.	Max.	Unit	Remark
TOP	Operating Temperature	0	+50	[°C]	Note 2-1
TGS	Glass surface temperature (operation)	0	+65	[°C]	Note 2-1 Function judged only
HOP	Operation Humidity	5	90	[%RH]	Note 2-1
TST	Storage Temperature	-20	+60	[°C]	
HST	Storage Humidity	5	90	[%RH]	

Note 2-1: Temperature and relative humidity range are shown as the below figure.

1. 90% RH Max ($T_a \leq 39^\circ\text{C}$)
2. Max wet-bulb temperature at 39°C or less. ($T_a \leq 39^\circ\text{C}$)
3. No condensation

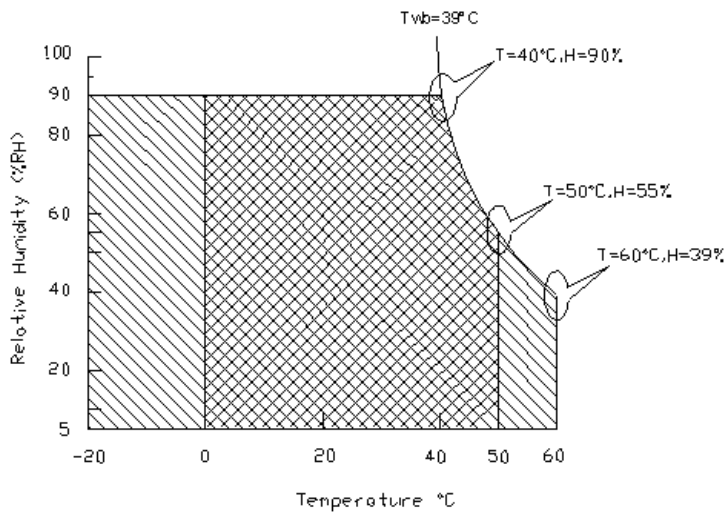

Operating Range



Storage Range

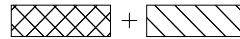

2.3 Optical Characteristics

The optical characteristics are measured on the following test condition.

Test Condition:

1. Equipment setup: Please refer to **Note 2-2**.
2. Panel Lighting time: 30 minutes
3. VDD=5.0V, Fv=60Hz, Is=110mA (typ.), Ta=25°C

Symbol	Description		Min.	Typ.	Max.	Unit	Remark
L _w	White Luminance (Center of screen)@110mA		280	350	-	[cd/m ²]	Note 2-2 By SR-3
	White Luminance (Center of screen)@100mA		240	300	-		
L _{uni}	Luminance Uniformity (9 points)		75	80	-	[%]	Note 2-3 By SR-3
CR	Contrast Ratio (Center of screen)		1800	3000	-	-	Note 2-4 By SR-3
θ _R	Horizontal Viewing Angle (CR=10)	Right	150	178	-	[degree]	Note 2-5 By SR-3
θ _L		Left	150	178	-		
Φ _H	Vertical Viewing Angle (CR=10)	Up	150	178	-		
Φ _L		Down	150	178	-		
θ _R	Horizontal Viewing Angle (CR=5)	Right	150	178	-		
θ _L		Left	150	178	-		
Φ _H	Vertical Viewing Angle (CR=5)	Up	150	178	-		
Φ _L		Down	150	178	-		
T _R	Response Time	Rising Time	-	7	17	[msec]	Note 2-6 By TRD-100
T _F		Falling Time	-	5	7		
-		Rising + Falling	-	12	24		
R _x	Color Coordinates (CIE 1931)	Red x	0.615	0.645	0.675	-	By SR-3
R _y		Red y	0.300	0.330	0.360		
G _x		Green x	0.285	0.315	0.345		
G _y		Green y	0.590	0.620	0.650		
B _x		Blue x	0.124	0.154	0.184		
B _y		Blue y	0.025	0.055	0.085		
W _x		White x	0.283	0.313	0.343		
W _y		White y	0.299	0.329	0.359		
CT	Crosstalk		-	-	1.5	[%]	Note 2-7 By SR-3

F _{dB}	Flicker (Center of screen)	-	-	-20	[dB]	Note 2-8 By SR-3
-----------------	----------------------------	---	---	-----	------	----------------------------

Note 2-2: Equipment setup :

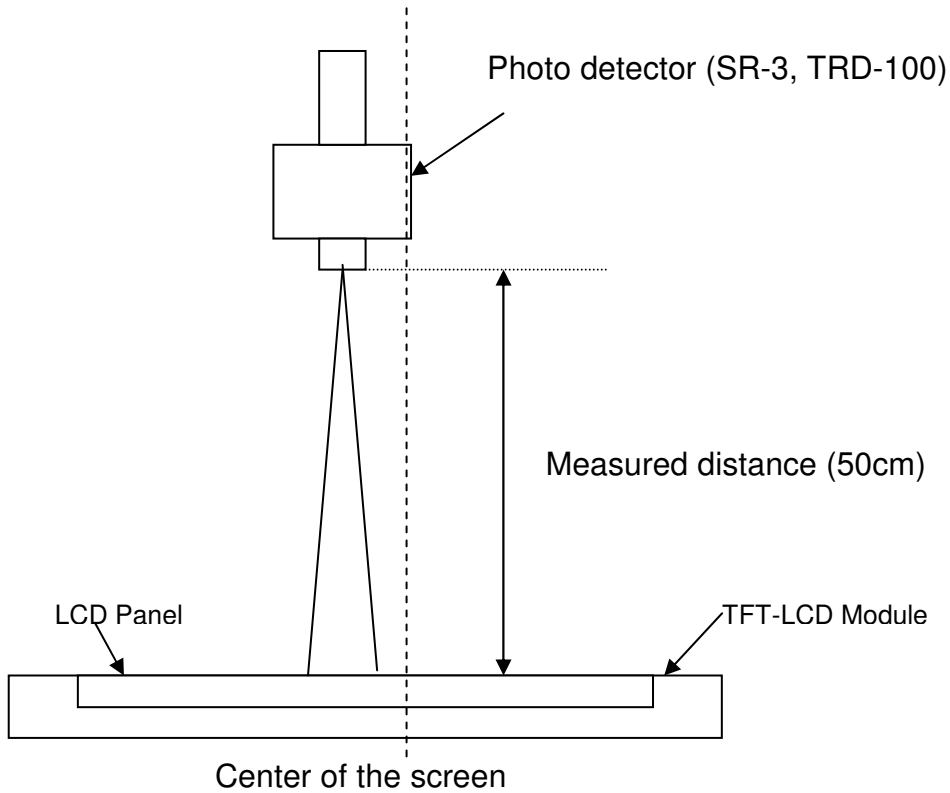

Note 2-3: Luminance Uniformity Measurement

Definition:

$$\text{Luminance Uniformity} = \frac{\text{Minimum Luminance of 9 Points (P1 ~ P9)}}{\text{Maximum Luminance of 9 Points (P1 ~ P9)}}$$

a. Test pattern: White Pattern

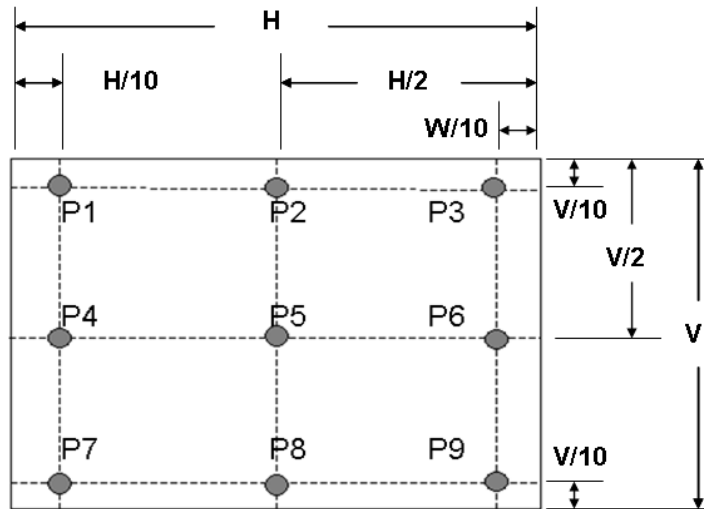

Note 2-4: Contrast Ratio Measurement

Definition:

$$\text{Contrast Ratio} = \frac{\text{Luminance of White pattern}}{\text{Luminance of Black pattern}}$$

- a. Measured position: Center of screen (P5) & perpendicular to the screen ($\theta = \Phi = 0^\circ$)

Note 2-5: Viewing angle measurement

Definition: The angle at which the contrast ratio is greater than 10 & 5.

- a. Horizontal view angle: Divide to left & right (θ_L & θ_R)
Vertical view angle: Divide to up & down (Φ_H & Φ_L)

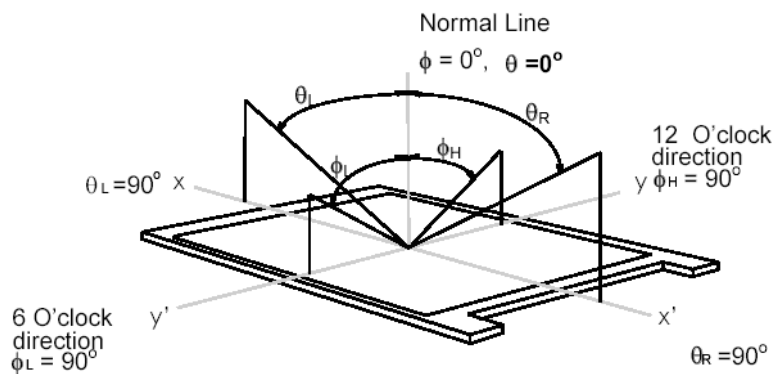

Note 2-6: Response time measurement

The output signals of photo detector are measured when the input signals are changed from “Black” to “White” (rising time, T_R), and from “White” to “Black” (falling time, T_F), respectively. The response time is interval between the 10% and 90% of optical response. (*Black & White color definition: Please refer section 3.4.3*)

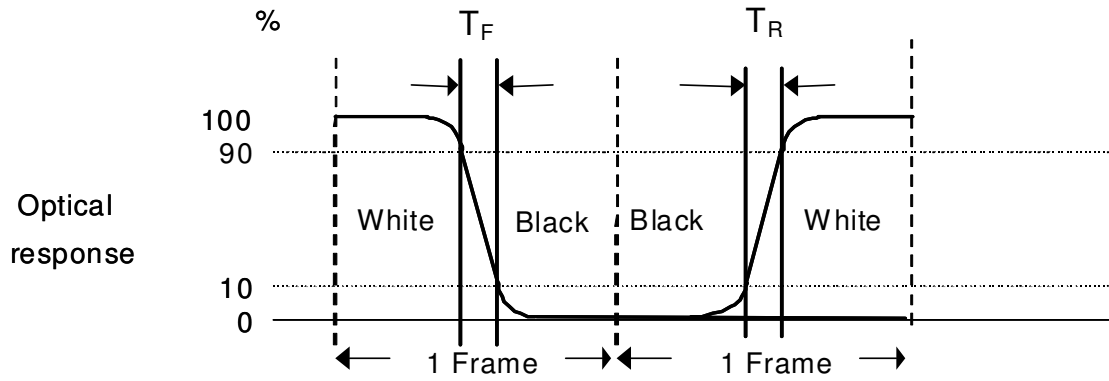

Note 2-7: Crosstalk measurement

Definition:

$$CT = \text{Max. } (CT_H, CT_V);$$

Where

a. Maximum Horizontal Crosstalk :

$$CT_H = \text{Max. } (|Y_{BL} - Y_{AL}| / Y_{AL} \times 100\%, |Y_{BR} - Y_{AR}| / Y_{AR} \times 100\%);$$

Maximum Vertical Crosstalk:

$$CT_V = \text{Max. } (|Y_{BU} - Y_{AU}| / Y_{AU} \times 100\%, |Y_{BD} - Y_{AD}| / Y_{AD} \times 100\%);$$

b. $Y_{AU}, Y_{AD}, Y_{AL}, Y_{AR}$ = Luminance of measured location without Black pattern

$Y_{BU}, Y_{BD}, Y_{BL}, Y_{BR}$ = Luminance of measured location with Black pattern

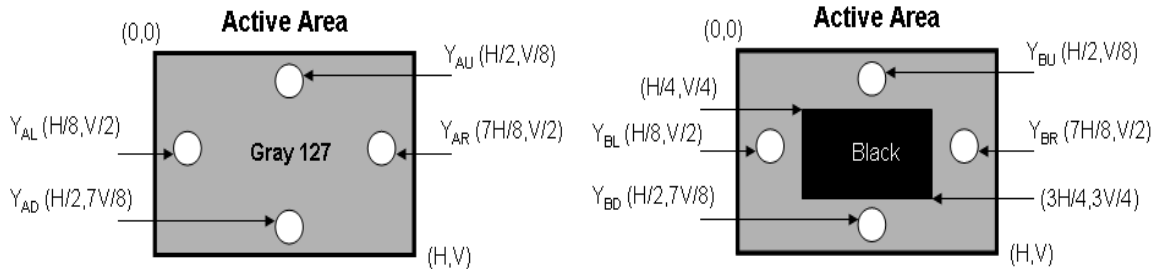

Note 2-8: Flicker measurement

a. Test pattern: It is listed as following.

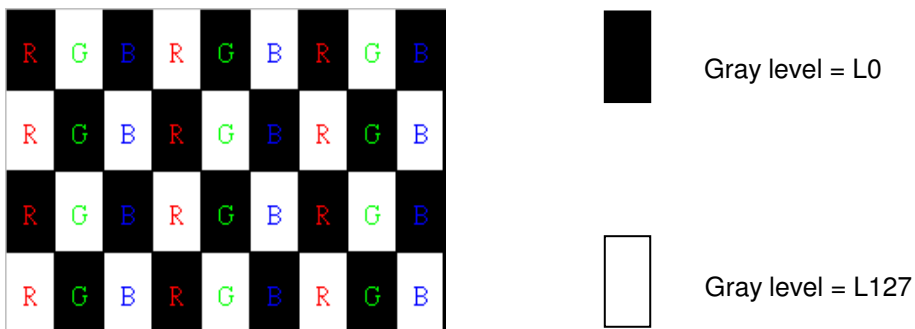

R: Red, G: Green, B:Blue

b. Measured position: Center of screen (P5) & perpendicular to the screen ($\theta = \Phi = 0^\circ$)

3 TFT-LCD Module

3.1 Block Diagram

The following shows the block diagram of the 27.0 inch Color TFT-LCD Module.

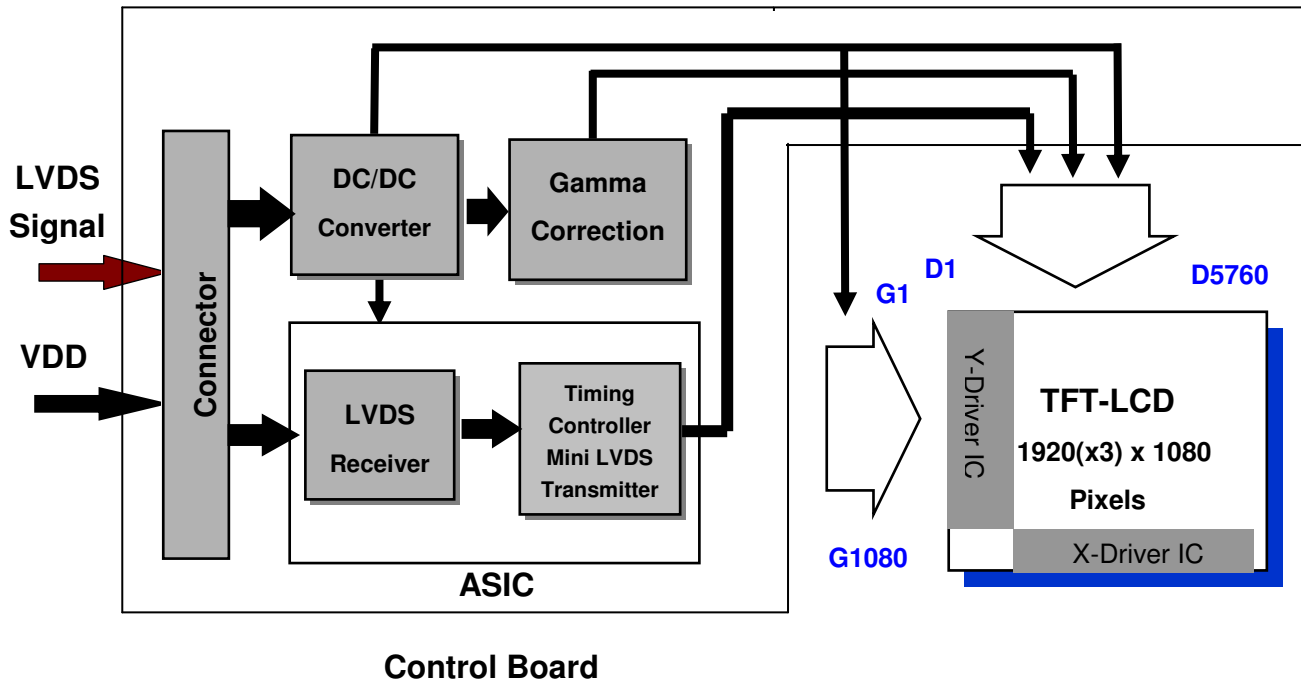

3.2 Interface Connection

3.2.1 Connector Type

TFT-LCD Connector	Manufacturer	P-TWO	STM
	Part Number	AL230F-A0G1D-P	MSCKT2407P30HB
Mating Connector	Manufacturer	JAE	
	Part Number	FI-X30HL (Locked Type)	

3.2.2 Connector Pin Assignment

PIN #	Symbol	Description	Remark
1	RxO0-	Negative LVDS differential data input (Odd data)	
2	RxO0+	Positive LVDS differential data input (Odd data)	
3	RxO1-	Negative LVDS differential data input (Odd data)	
4	RxO1+	Positive LVDS differential data input (Odd data)	
5	RxO2-	Negative LVDS differential data input (Odd data)	
6	RxO2+	Positive LVDS differential data input (Odd data)	
7	GND	Ground	
8	RxOCLK-	Negative LVDS differential clock input (Odd clock)	
9	RxOCLK+	Positive LVDS differential clock input (Odd clock)	
10	RxO3-	Negative LVDS differential data input (Odd data)	
11	RxO3+	Positive LVDS differential data input (Odd data)	
12	RxE0-	Negative LVDS differential data input (Even data)	
13	RxE0+	Positive LVDS differential data input (Even data)	
14	GND	Ground	
15	RxE1-	Negative LVDS differential data input (Even data)	
16	RxE1+	Positive LVDS differential data input (Even data)	
17	GND	Ground	
18	RxE2-	Negative LVDS differential data input (Even data)	
19	RxE2+	Positive LVDS differential data input (Even data)	
20	RxECLK-	Negative LVDS differential clock input (Even clock)	
21	RxECLK+	Positive LVDS differential clock input (Even clock)	
22	RxE3-	Negative LVDS differential data input (Even data)	
23	RxE3+	Positive LVDS differential data input (Even data)	
24	GND	Ground	
25	NC	No connection (for AUO test only. Do not connect)	
26	NC	No connection (for AUO test only. Do not connect)	

27	NC	No connection (for AUO test only. Do not connect)	
28	VDD	Power Supply Input Voltage	
29	VDD	Power Supply Input Voltage	
30	VDD	Power Supply Input Voltage	

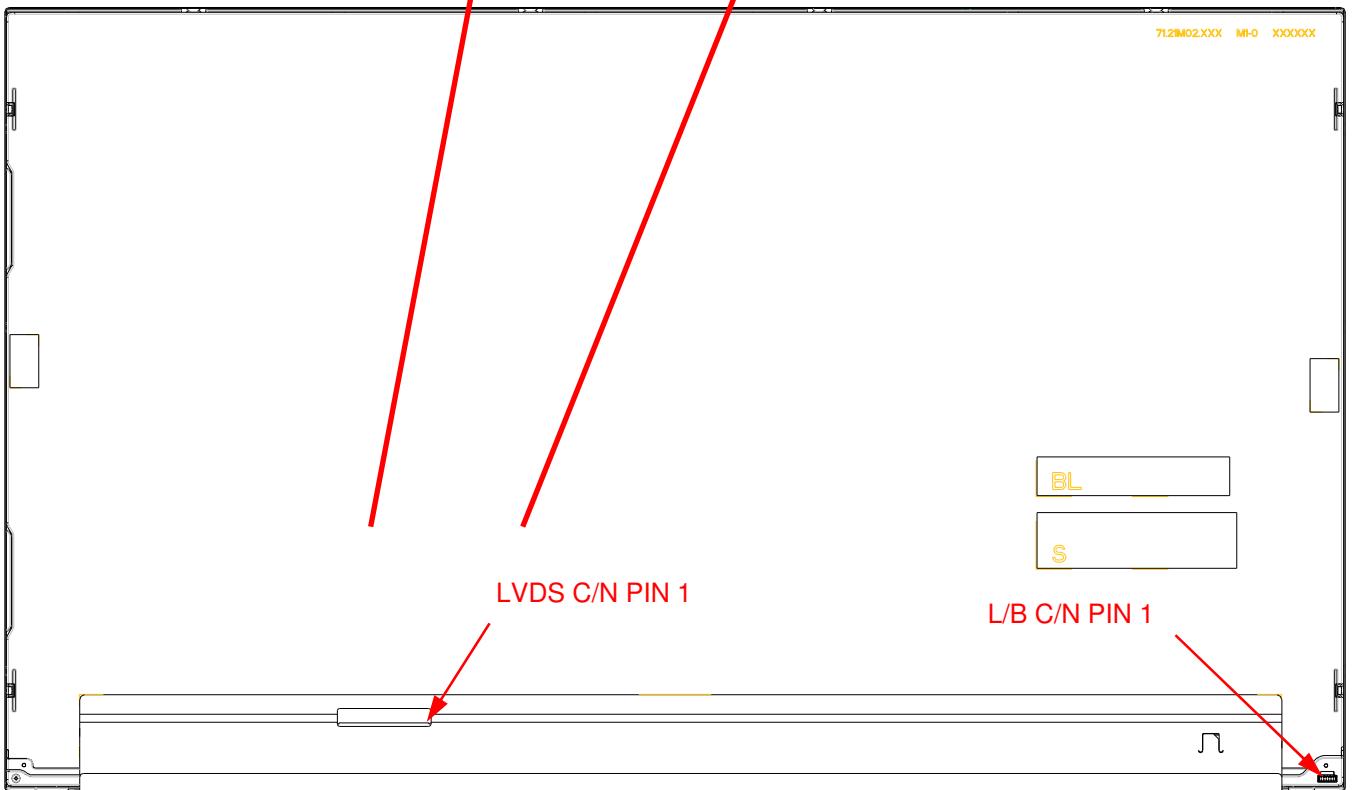
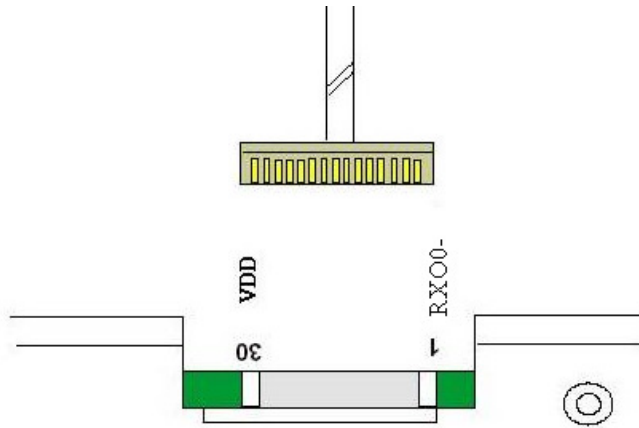

3.3 Electrical Characteristics

3.3.1 Absolute Maximum Rating

Permanent damage may occur if exceeding the following maximum rating.

Symbol	Description	Min	Max	Unit	Remark
VDD	Power Supply Input Voltage	GND-0.3	6.0	[Volt]	Ta=25°C

3.3.2 Recommended Operating Condition

Symbol	Description	Min	Typ	Max	Unit	Remark
VDD	Power supply Input voltage	4.5	5.0	5.5	[Volt]	
IDD	Power supply Input Current (RMS)	-	1.02	1.22	[A]	VDD= 5.0V, Black Pattern, Fv=60Hz
		-	1.21	1.45	[A]	VDD= 5.0V, Black Pattern, Fv=75Hz
PDD	VDD Power Consumption	-	5.1	6.12	[Watt]	VDD= 5.0V, Black Pattern, Fv=60Hz
		-	6.05	7.26	[Watt]	VDD= 5.0V, Black Pattern, Fv=75Hz
IRush	Inrush Current	-	-	3.0	[A]	Note 3-1
VDDrp	Allowable VDD Ripple Voltage	-	-	500	[mV]	VDD= 5.0V, Black Pattern, Fv=75Hz

Note 3-1: Inrush Current measurement:

Test circuit:

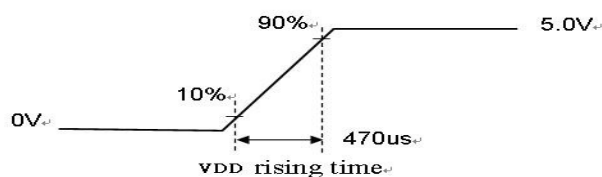
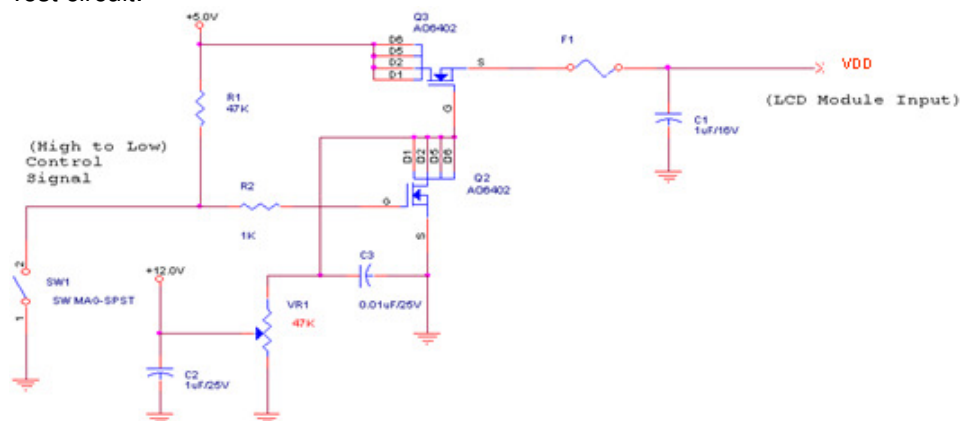

The duration of VDD rising time: 470µs.

3.4 Signal Characteristics

3.4.1 LCD Pixel Format

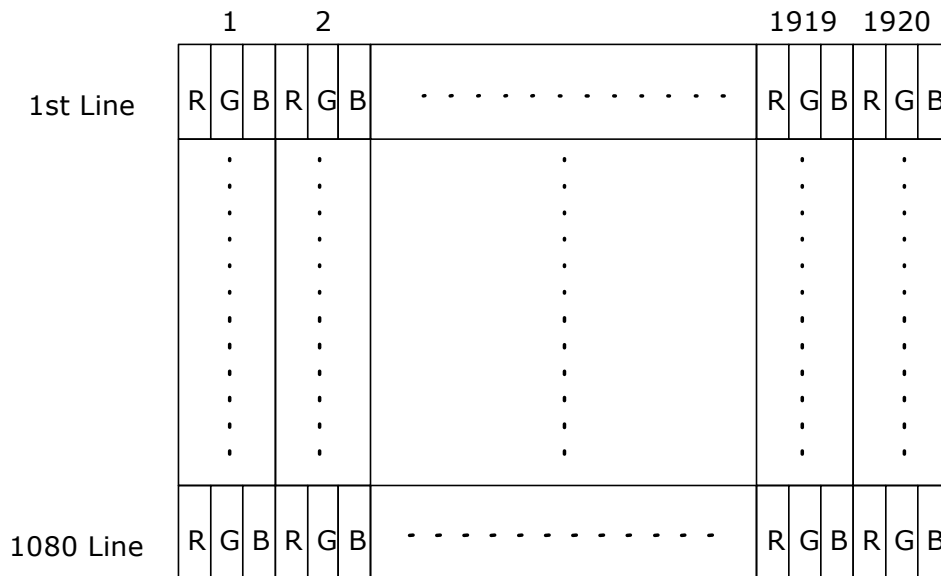

3.4.2 LVDS Data Format

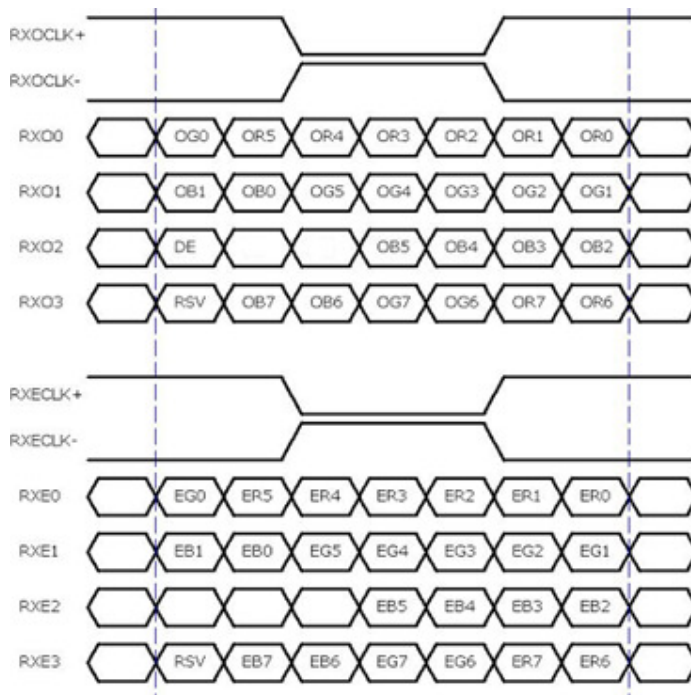

8 Bit Color Bit Order			
MSB	R7	G7	B7
	R6	G6	B6
	R5	G5	B5
	R4	G4	B4
	R3	G3	B3
	R2	G2	B2
	R1	G1	B1
LSB	R0	G0	B0

Note 3-2:

- a. O = "Odd Pixel Data" E = "Even Pixel Data"
- b. Refer to 3.4.1 LCD pixel format, the 1st data is 1 (Odd Pixel Data), the 2nd data is 2 (Even Pixel Data) and the last data is 1920 (Even Pixel Data).

3.4.3 Color versus Input Data

The following table is for color versus input data (8bit). The higher the gray level, the brighter the color.

Color	Gray Level	Color Input Data																								Remark
		RED data (MSB:R7, LSB:R0)								GREEN data (MSB:G7, LSB:G0)								BLUE data (MSB:B7, LSB:B0)								
		R7	R6	R5	R4	R3	R2	R1	R0	G7	G6	G5	G4	G3	G2	G1	G0	B7	B6	B5	B4	B3	B2	B1	B0	
Black	-	0	0	0	0	0	0	0	0	0	0	0	0	0	0	0	0	0	0	0	0	0	0	0	0	
White	-	1	1	1	1	1	1	1	1	1	1	1	1	1	1	1	1	1	1	1	1	1	1	1	1	
Gray 127	-	0	1	1	1	1	1	1	1	0	1	1	1	1	1	1	1	0	1	1	1	1	1	1	1	
Red	L0	0	0	0	0	0	0	0	0	0	0	0	0	0	0	0	0	0	0	0	0	0	0	0	0	Black
	:	:	:	:	:	:	:	:	:	:	:	:	:	:	:	:	:	:	:	:	:	:	:	:	:	
	L255	1	1	1	1	1	1	1	1	0	0	0	0	0	0	0	0	0	0	0	0	0	0	0	0	
Green	L0	0	0	0	0	0	0	0	0	0	0	0	0	0	0	0	0	0	0	0	0	0	0	0	0	Black
	:	:	:	:	:	:	:	:	:	:	:	:	:	:	:	:	:	:	:	:	:	:	:	:	:	
	L255	0	0	0	0	0	0	0	0	1	1	1	1	1	1	1	1	0	0	0	0	0	0	0	0	
Blue	L0	0	0	0	0	0	0	0	0	0	0	0	0	0	0	0	0	0	0	0	0	0	0	0	0	Black
	:	:	:	:	:	:	:	:	:	:	:	:	:	:	:	:	:	:	:	:	:	:	:	:	:	
	L255	0	0	0	0	0	0	0	0	0	0	0	0	0	0	0	0	1	1	1	1	1	1	1	1	

3.4.4 LVDS Specification

a. DC Characteristics:

Symbol	Description	Min	Typ	Max	Units	Condition
V_{TH}	LVDS Differential Input High Threshold	-	-	+100	[mV]	$V_{CM} = 1.2V$
V_{TL}	LVDS Differential Input Low Threshold	-100	-	-	[mV]	$V_{CM} = 1.2V$
$ V_{ID} $	LVDS Differential Input Voltage	100	-	600	[mV]	
V_{CM}	LVDS Common Mode Voltage	+1.0	+1.2	+1.5	[V]	$V_{TH} - V_{TL} = 200mV$

LVDS Signal Waveform:

Use RxOCLK- & RxOCLK+ as example.

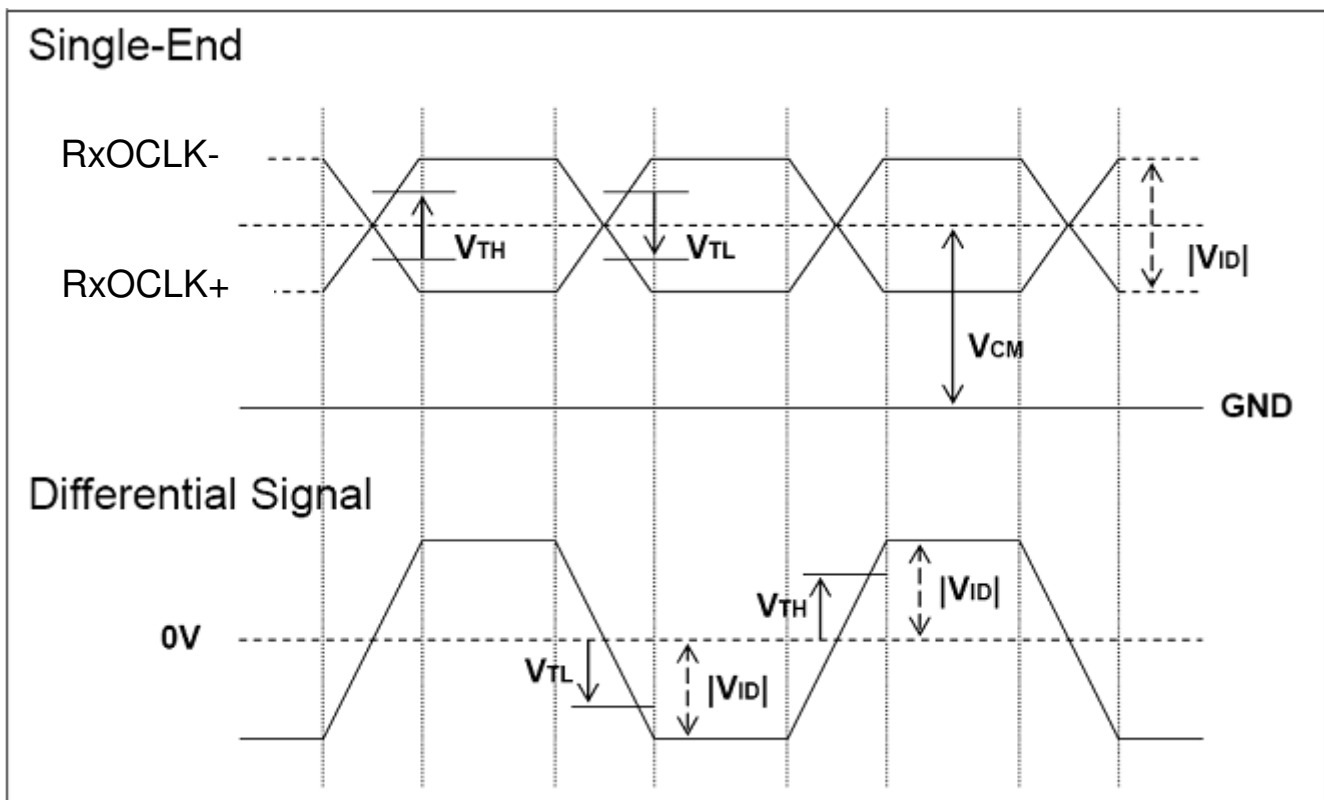

b. AC Characteristics:

Symbol	Description	Min	Max	Unit	Remark
F_{DEV}	Maximum deviation of input clock frequency during Spread Spectrum	-	± 3	%	
F_{MOD}	Maximum modulation frequency of input clock during Spread Spectrum	-	200	KHz	

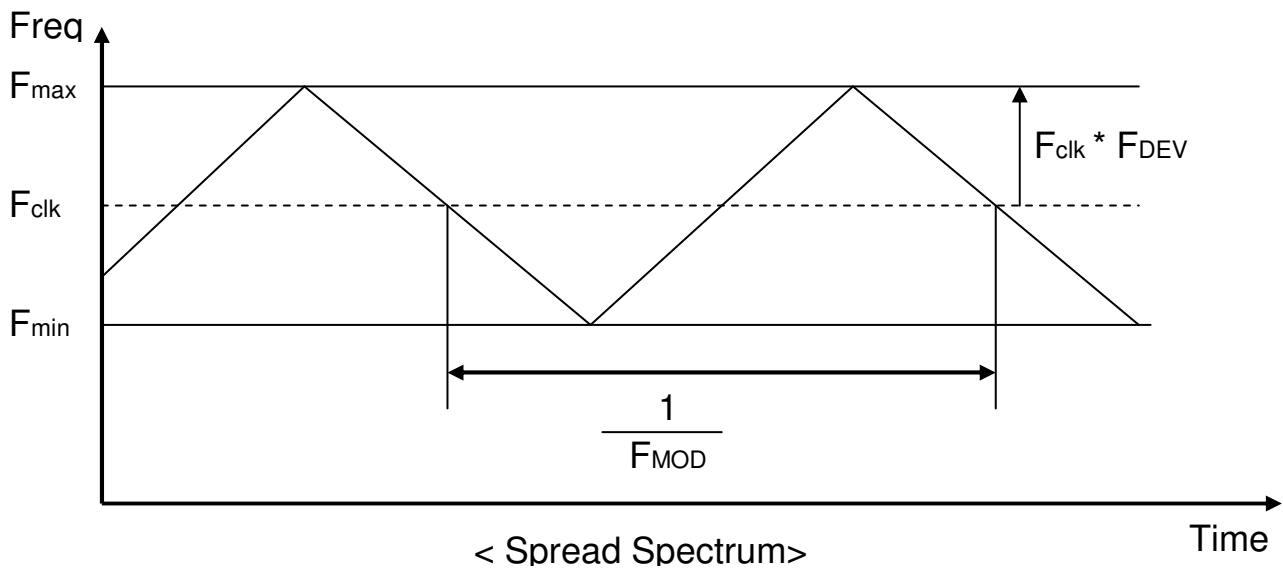

Fclk: LVDS Clock Frequency

3.4.5 Input Timing Specification

It only support DE mode, and the input timing are shown as the following table.

Symbol	Description		Min.	Typ.	Max.	Unit	Remark
Tv	Vertical Section	Period	1092	1130	1793	Th	
Tdisp (v)		Active	1080	1080	1080	Th	
Tblk (v)		Blanking	12	50	713	Th	
Fv		Frequency	50	60	76	Hz	
Th	Horizontal Section	Period	1004	1050	1100	Tclk	
Tdisp (h)		Active	960	960	960	Tclk	
Tblk (h)		Blanking	44	90	140	Tclk	
Fh		Frequency	55	68	90	KHz	Note 3-3
Tclk	LVDS Clock	Period	11.1	14.0	18.2	ns	1/Fclk
Fclk		Frequency	54.8	71.2	90.0	MHz	Note 3-4

Note 3-3: The equation is listed as following. Please don't exceed the above recommended value.

$$Fh \text{ (Min.)} = Fclk \text{ (Min.)} / Th \text{ (Min.)};$$

$$Fh \text{ (Typ.)} = Fclk \text{ (Typ.)} / Th \text{ (Typ.)};$$

$$Fh \text{ (Max.)} = Fclk \text{ (Max.)} / Th \text{ (Min.)};$$

Note 3-4: The equation is listed as following. Please don't exceed the above recommended value.

$$Fclk \text{ (Min.)} = Fv \text{ (Min.)} \times Th \text{ (Min.)} \times Tv \text{ (Min.)};$$

$$Fclk \text{ (Typ.)} = Fv \text{ (Typ.)} \times Th \text{ (Typ.)} \times Tv \text{ (Typ.)};$$

$$Fclk \text{ (Max.)} = Fv \text{ (Max.)} \times Th \text{ (Typ.)} \times Tv \text{ (Typ.)};$$

3.4.6 Input Timing Diagram

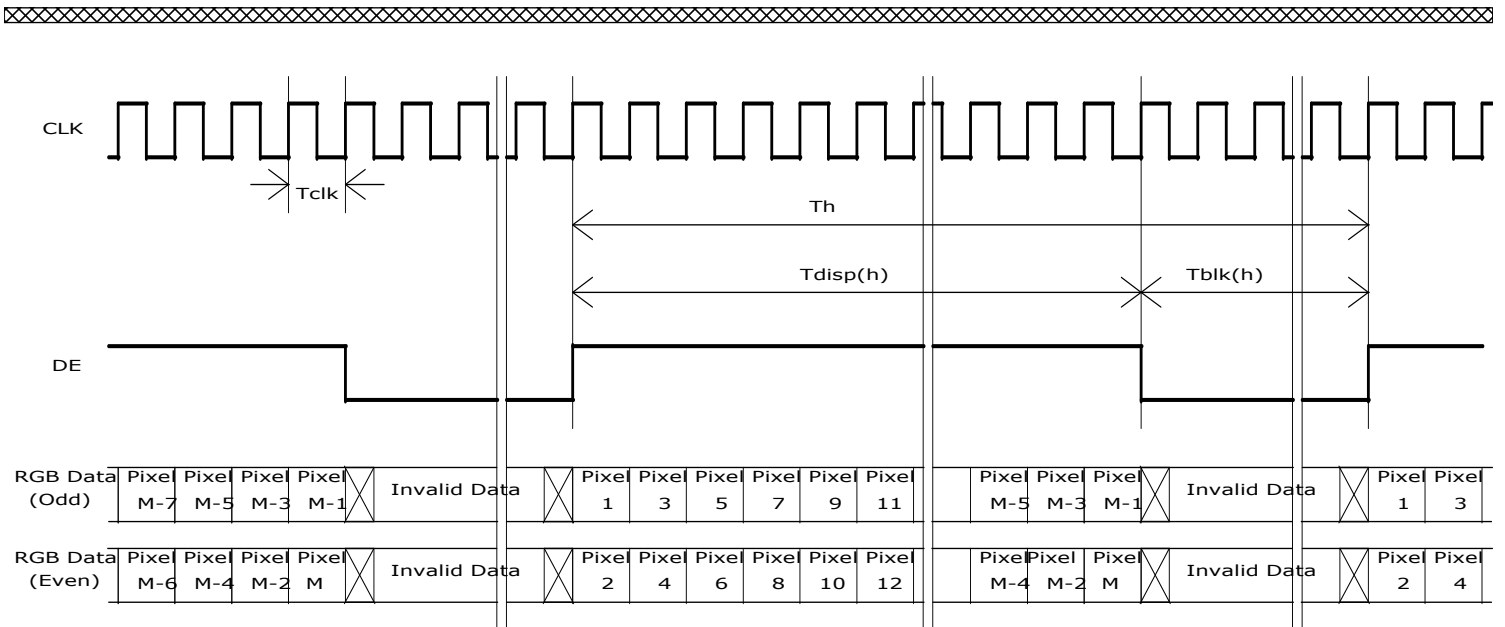
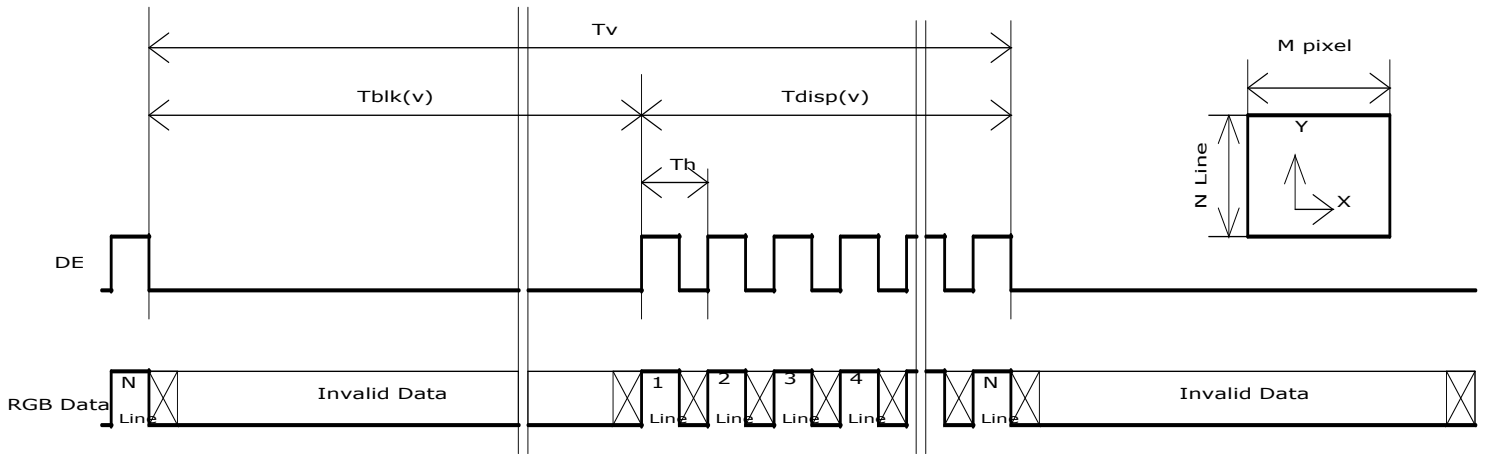

3.5 Power ON/OFF Sequence

VDD power, LVDS signal and backlight on/off sequence are as following. LVDS signals from any system shall be Hi-Z state when VDD is off.

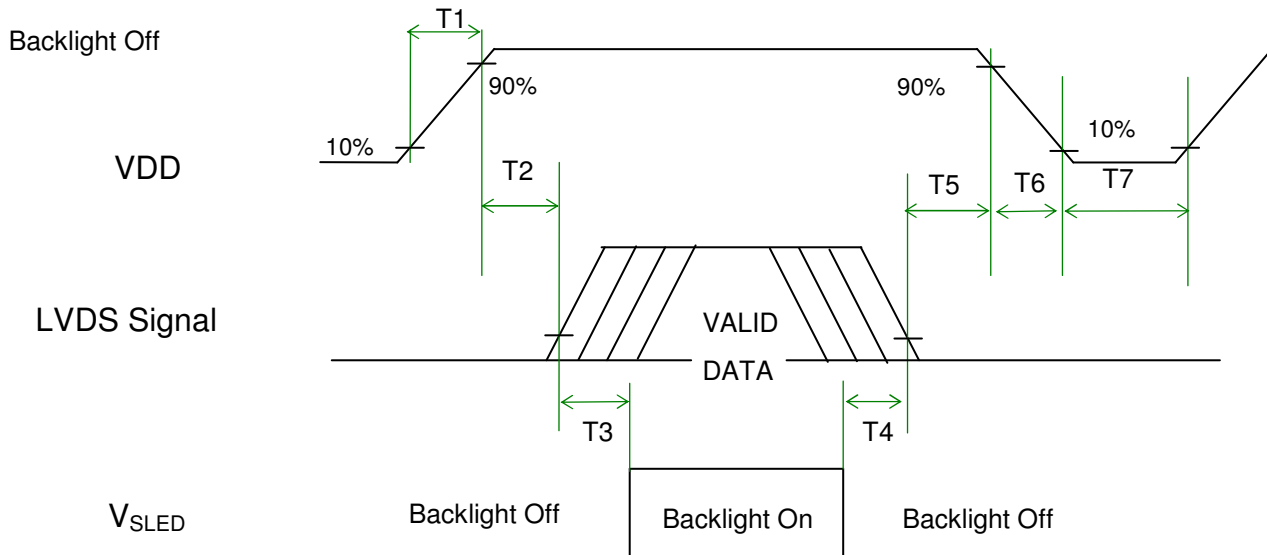

Power Sequence Timing

Symbol	Value			Unit	Remark
	Min.	Typ.	Max.		
T1	0.5	-	10	[ms]	
T2	0	-	50	[ms]	
T3	500	-	-	[ms]	
T4	100	-	-	[ms]	
T5	0	-	50	[ms]	Note 3-5 Note 3-6
T6	5	-	100	[ms]	Note 3-6
T7	1000	-	-	[ms]	

Note 3-5 : Recommend setting T5 = 0ms to avoid electronic noise when VDD is off.

Note 3-6 : During T5 and T6 period , please keep the level of input LVDS signals with Hi-Z state.

4 Backlight Unit

4.1 Block Diagram

The following shows the block diagram of the 27.0 inch Backlight Unit. And it includes 60pcs LED in the LED light bar. (4 strings and 15 pcs LED of one string).

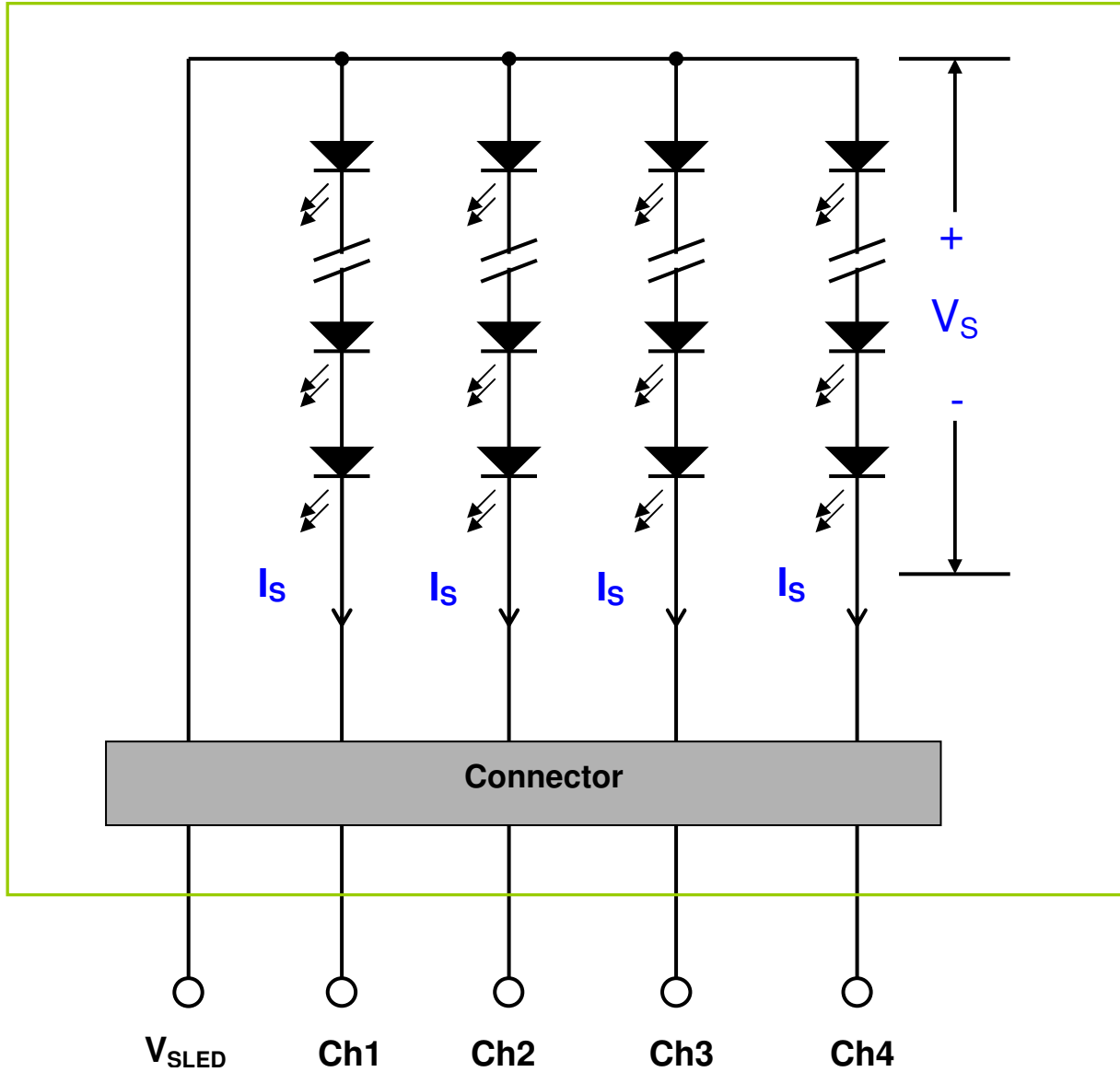

4.2 Interface Connection

4.2.1 Connector Type

Backlight Connector	Manufacturer	ENTERY
	Part Number	3707K-S06N-21R
Mating Connector	Manufacturer	ENTERY
	Part Number	H112K-P06N-13B (Locking type)

Backlight Connector dimension:

$H \times V \times D = 13.9 \times 3.00 \times 4.25$, Pitch = 1.0(unit = mm)

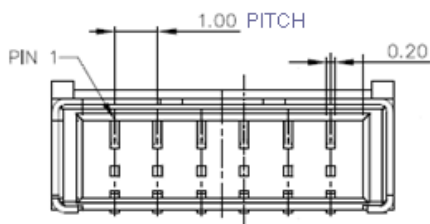
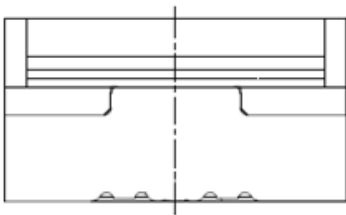

Mating Connector dimension:

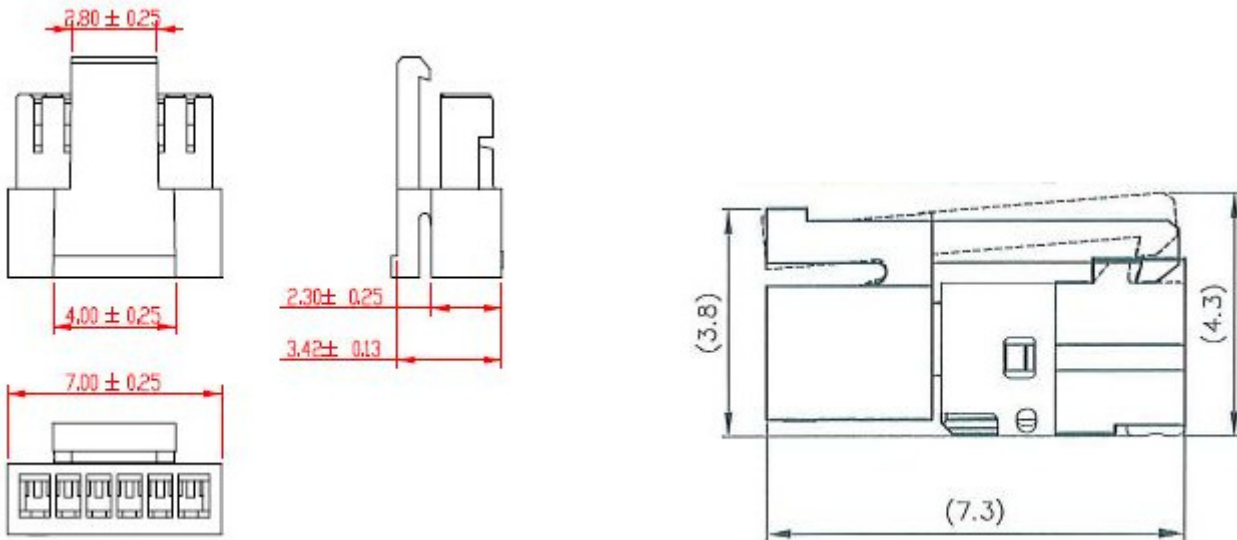

4.2.2 Connector Pin Assignment

Pin#	Symbol	Description	Remark
1	Ch1	LED Current Feedback Terminal (Channel 1)	
2	Ch2	LED Current Feedback Terminal (Channel 2)	
3	V _{SLED}	LED Power Supply Voltage Input Terminal	
4	V _{SLED}	LED Power Supply Voltage Input Terminal	
5	Ch3	LED Current Feedback Terminal (Channel 3)	
6	Ch4	LED Current Feedback Terminal (Channel 4)	

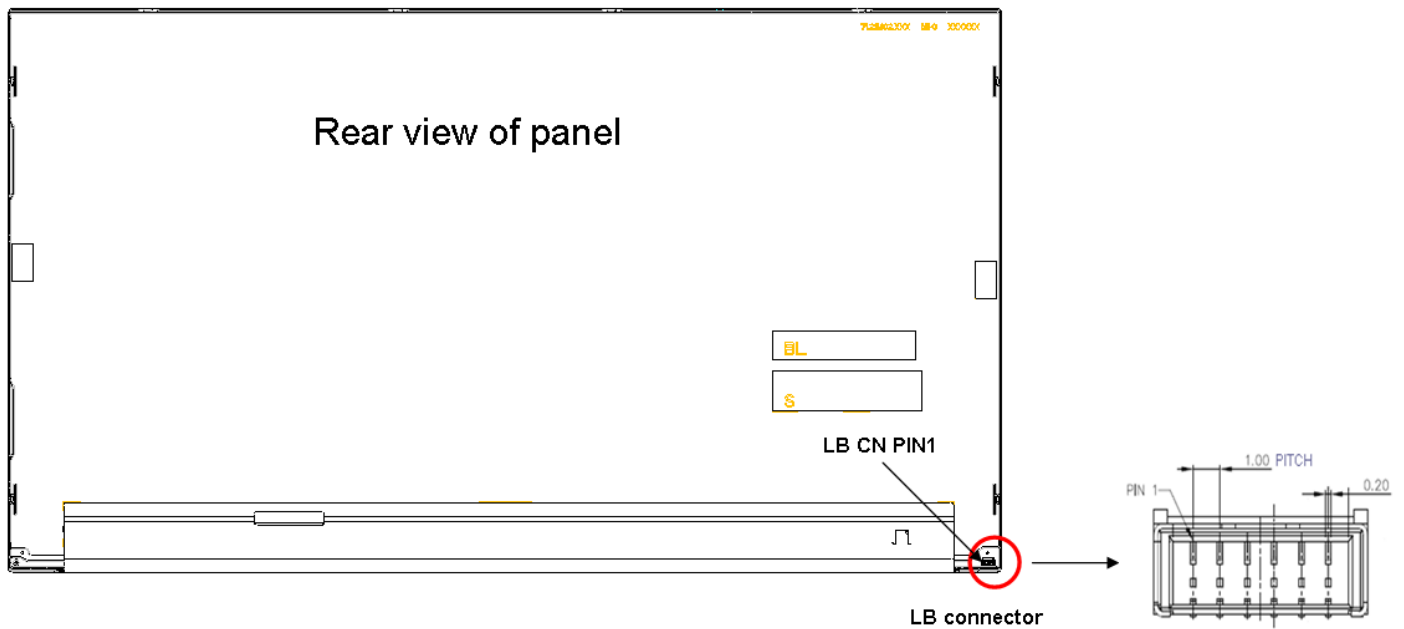

4.3 Electrical Characteristics

4.3.1 Absolute Maximum Rating

Permanent damage may occur if exceeding the following maximum rating.

(Ta=25°C)

Symbol	Description	Min	Max	Unit	Remark
Is	LED String Current	0	150	[mA]	100% duty ratio
			210	[mA]	Duty ratio ≤ 10% Pulse time=10 ms

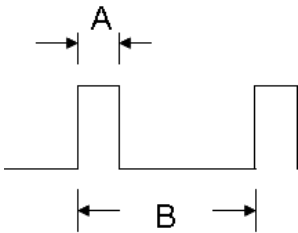

Duty ratio= (A / B) X 100% ; (A: Pulse time, B: Period)

4.3.2 Recommended Operating Condition

(Ta=25°C)

Symbol	Description	Min.	Typ.	Max.	Unit	Remark
Is	LED String Current	-	110	115.5	[mA]	100% duty ratio of LED chip
Vs	LED String Voltage	44.25	49.5	54	[Volt]	Is=60mA @ 100% duty ratio; Note 4-1 , Note 4-5
ΔVs	Maximum Vs Voltage Deviation of light bar	-	-	3	[Volt]	Is=60mA @ 100% duty ratio; Note 4-2
P _{BLU}	LED Light Bar Power Consumption	-	21.78	23.76	[Watt]	Note 4-3
LT _{LED}	LED Life Time	30,000	-	-	[Hour]	Note 4-4

Note 4-1: $V_s (\text{Typ.}) = V_F (\text{Typ.}) \times \text{LED No. (one string)}$;

- a. V_F : LED chip forward voltage, $V_F (\text{Min.})=2.8\text{V}$, $V_F (\text{Typ.})=3.2\text{V}$, $V_F (\text{Max.})=3.4\text{V}$
- b. The same equation to calculate $V_s (\text{Min.})$ & $V_s (\text{Max.})$ for respective $V_F (\text{Min.})$ & $V_F (\text{Max.})$;

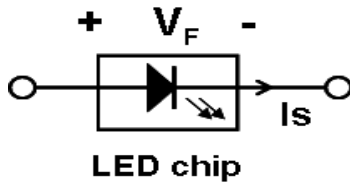

Note 4-2: $\Delta V_s (\text{Max.}) = \Delta V_F \times \text{LED No. (one string)}$;

- a. ΔV_F : LED chip forward voltage deviation; (0.2 V , each Bin of LED V_F)

Note 4-3: $P_{\text{BLU}} (\text{Typ.}) = V_s (\text{Typ.}) \times I_s (\text{Typ.}) \times 4$; (4 is total String No. of LED Light bar)

$P_{\text{BLU}} (\text{Max.}) = V_s (\text{Max.}) \times I_s (\text{Typ.}) \times 4$;

Note 4-4: Definition of life time:

- a. Brightness of LED becomes to 50% of its original value
- b. Test condition: $I_s = 110\text{mA}$ and 25°C (Room Temperature)

Note 4-5: Recommendation for LED driver power design:

Due to there are electrical property deviation in LED & monitor set system component after long time operation. AUO strongly recommend the design value of LED driver board OVP (over voltage protection) should be 10% higher than max. value of LED string voltage (V_s) at least.



5 Reliability Test

AUO reliability test items are listed as following table. (*Bare Panel only*)

Items	Condition	Remark
Temperature Humidity Bias (THB)	Ta= 50°C, 80%RH, 300hours	
High Temperature Operation (HTO)	Ta= 50°C, 50%RH, 300hours	
Low Temperature Operation (LTO)	Ta= 0°C, 300hours	
High Temperature Storage (HTS)	Ta= 60°C, 300hours	
Low Temperature Storage (LTS)	Ta= -20°C, 300hours	
Vibration Test (Non-operation)	Acceleration: 1.5 Grms Wave: Random Frequency: 10 - 200 Hz Sweep: 30 Minutes each Axis (X, Y, Z)	
Shock Test (Non-operation)	Acceleration: 50 G Wave: Half-sine Active Time: 20 ms Direction: ±X, ±Y, ±Z (one time for each Axis)	
Drop Test	Height: 60 cm, package test	
Thermal Shock Test (TST)	-20°C/30min, 60°C/30min, 100 cycles	Note 5-1
On/Off Test	On/10sec, Off/10sec, 30,000 cycles	
ESD (Electro Static Discharge)	Contact Discharge: ± 15KV, 150pF(330Ω) 1sec, 8 points, 25 times/ point.	Note 5-2
	Air Discharge: ± 15KV, 150pF(330Ω) 1sec 8 points, 25 times/ point.	
Altitude Test	Operation:18,000 ft Non-Operation:40,000 ft	

Note 5-1: a. A cycle of rapid temperature change consists of varying the temperature from -20°C to 60°C, and back again. Power is not applied during the test.
b. After finish temperature cycling, the unit is placed in normal room ambient for at least 4 hours before power on.

Note 5-2: EN61000-4-2, ESD class B: Certain performance degradation allowed

No data lost

Self-recoverable

No hardware failures.

6 Shipping Label

The label is on the panel as shown below:

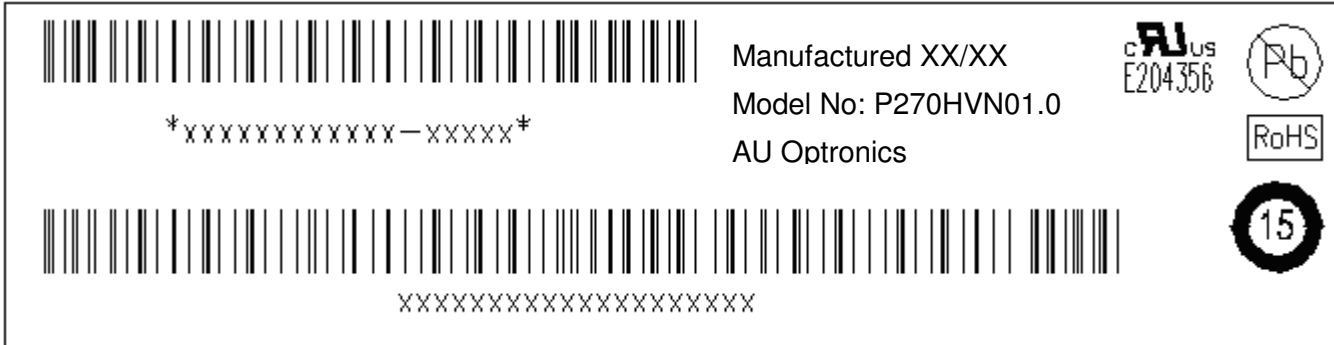

Note 6-1: For Pb Free products, AUO will add  for identification.

Note 6-2: For RoHS compatible products, AUO will add  for identification.

Note 6-3: For China RoHS compatible products, AUO will add  for identification.

Note 6-4: The Green Mark will be presented only when the green documents have been ready by AUO Internal Green Team.

7 Mechanical Characteristics

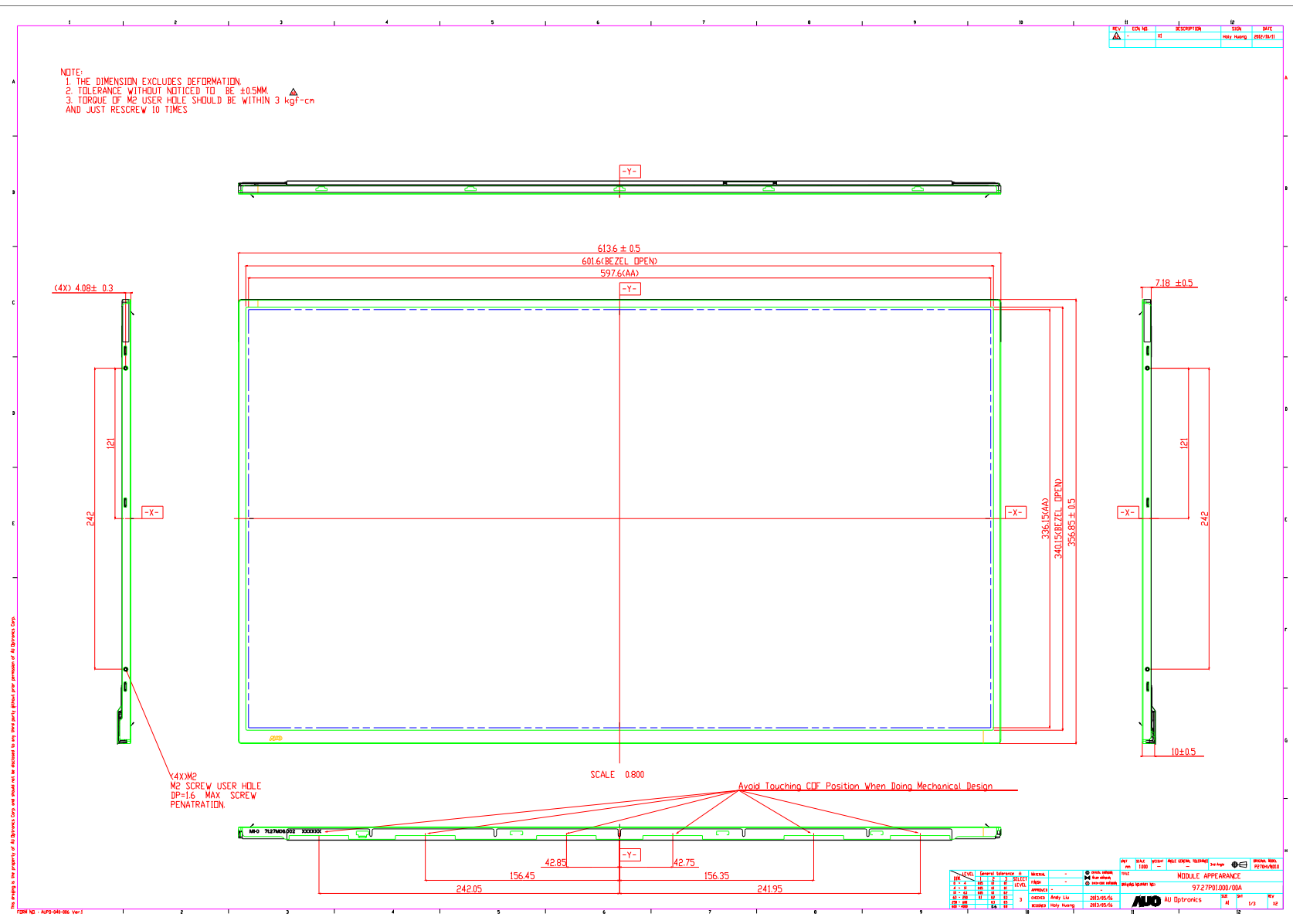

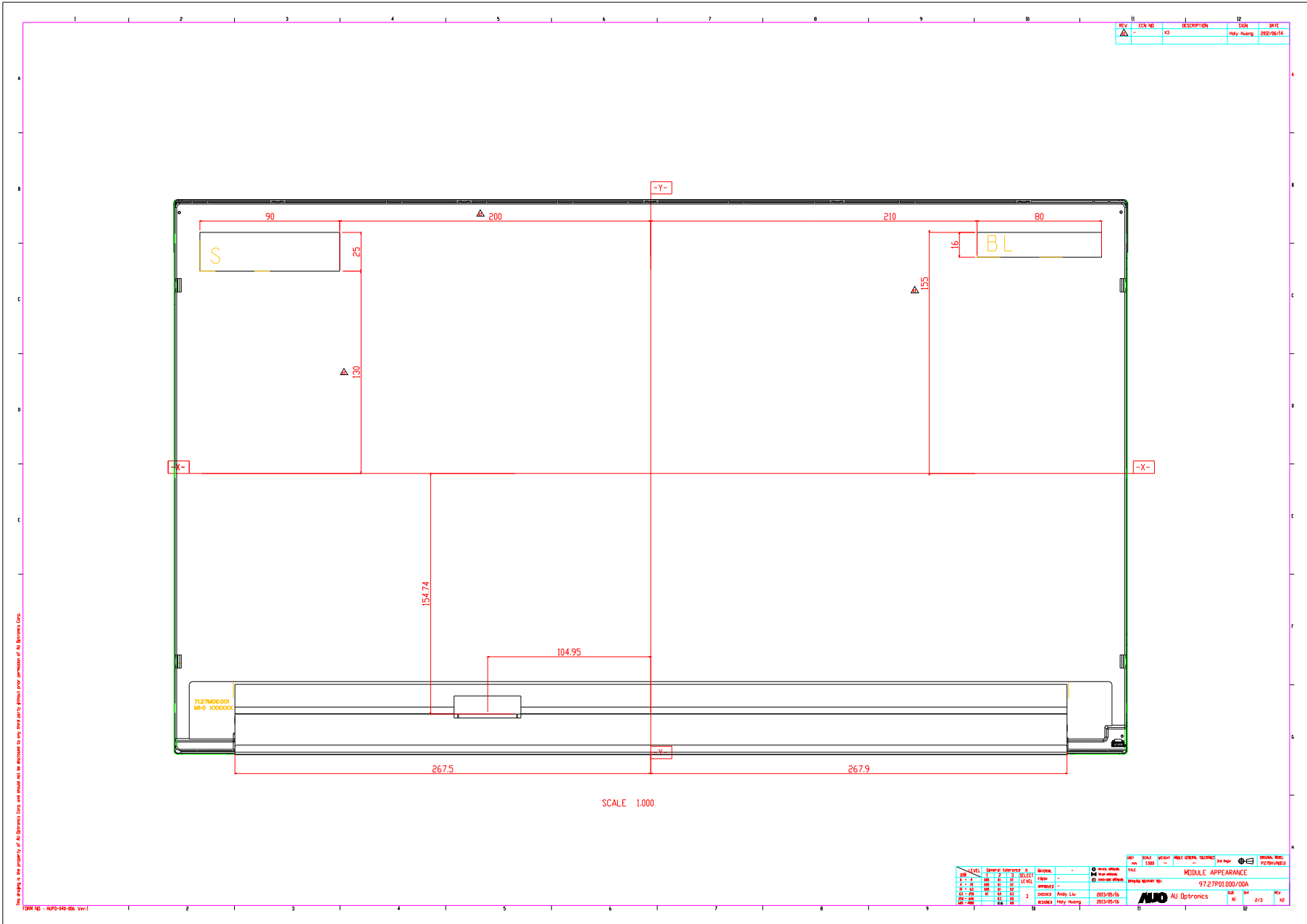

REV	CHK NO	DESCRIPTION	DATE	BY
-	03		2013/05/16	

REV	SCALE	WEIGHT	THICK	GENERAL	TOLERANCE	2nd Layer	DRILLING	NO.1	NO.2
01	1:000								

LEVEL	General Appearance	Material	Color	Thickness	Drill Hole	Drill Hole	Drill Hole	Drill Hole	Drill Hole
01	FR-4	FR-4	Green	1.6	0.3	0.3	0.3	0.3	0.3
02	FR-4	FR-4	Green	1.6	0.3	0.3	0.3	0.3	0.3
03	FR-4	FR-4	Green	1.6	0.3	0.3	0.3	0.3	0.3
04	FR-4	FR-4	Green	1.6	0.3	0.3	0.3	0.3	0.3
05	FR-4	FR-4	Green	1.6	0.3	0.3	0.3	0.3	0.3
06	FR-4	FR-4	Green	1.6	0.3	0.3	0.3	0.3	0.3
07	FR-4	FR-4	Green	1.6	0.3	0.3	0.3	0.3	0.3
08	FR-4	FR-4	Green	1.6	0.3	0.3	0.3	0.3	0.3
09	FR-4	FR-4	Green	1.6	0.3	0.3	0.3	0.3	0.3
10	FR-4	FR-4	Green	1.6	0.3	0.3	0.3	0.3	0.3

DATE	SCALE	WEIGHT	THICK	GENERAL	TOLERANCE	2nd Layer	DRILLING	NO.1	NO.2
2013/05/16	1:000								

8 Packing Specification

8.1 Packing Flow

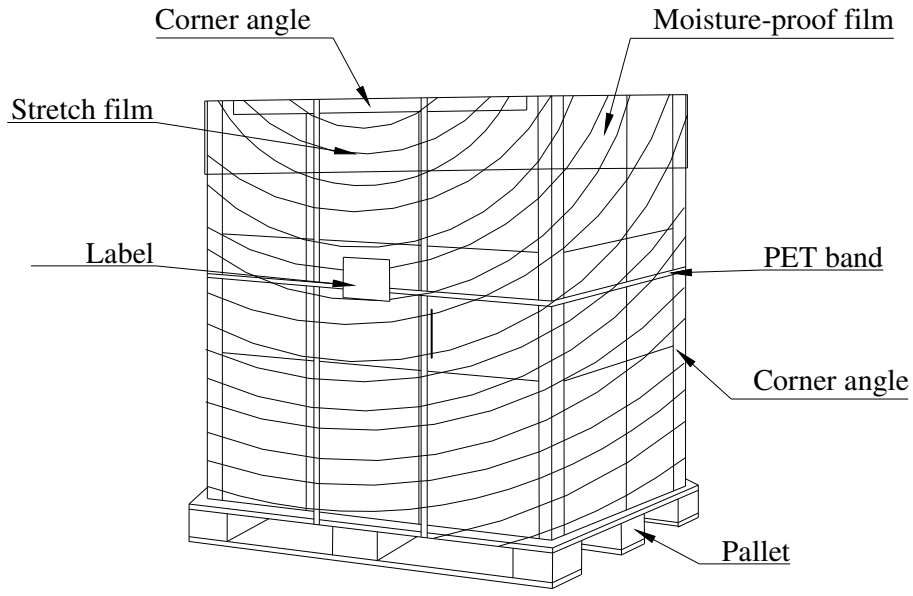
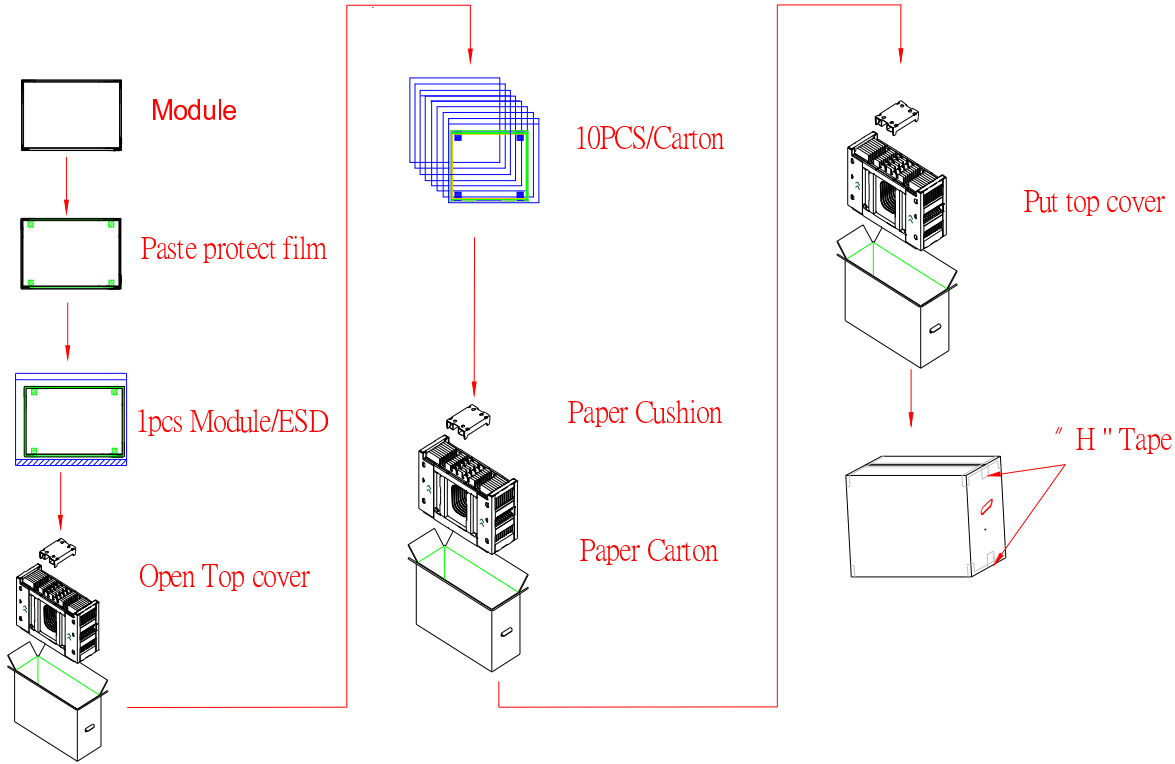

8.2 Pallet and shipment information

Item	Specification			Remark
	Q'ty	Dimension	Weight(kg)	
Panel	1	613.6(H)mm x 356.85(V)mm x 10(D)mm	2.180	
Cushion	1	-	4.41	
Box	1	708(L)mm x 261(W)mm x 473(H)mm	1.38	without Panel & cushion
Packing Box	10 pcs/Box	708(L)mm x 261(W)mm x 473(H)mm	27.13	with panel & cushion
Pallet	1	1070(L)mm x 740(W)mm x 138(H)mm	12.9	
Pallet after Packing	8 boxes/pallet	1070(L)mm x 740(W)mm x 138(H)mm	229.94	